

GENERAL NOTES

1. BRASS DIAL MAY BE CONFIGURED TO SUIT RUDDER TRAVEL OF ANY VESSEL; PLEASE SPECIFY WHEN ORDERING.
2. CLEARANCE DEPTH DEPENDS ON NUMBER OF LAYERS ON POTENTIOMETER, APPROX. 3/4" PER LAYER.
3. PLEASE SPECIFY NUMBER OF LAYERS NEEDED ON POTENTIOMETER WHEN ORDERING REPLACEMENT UNITS.
4. WEIGHT IS 4.1 LBS.

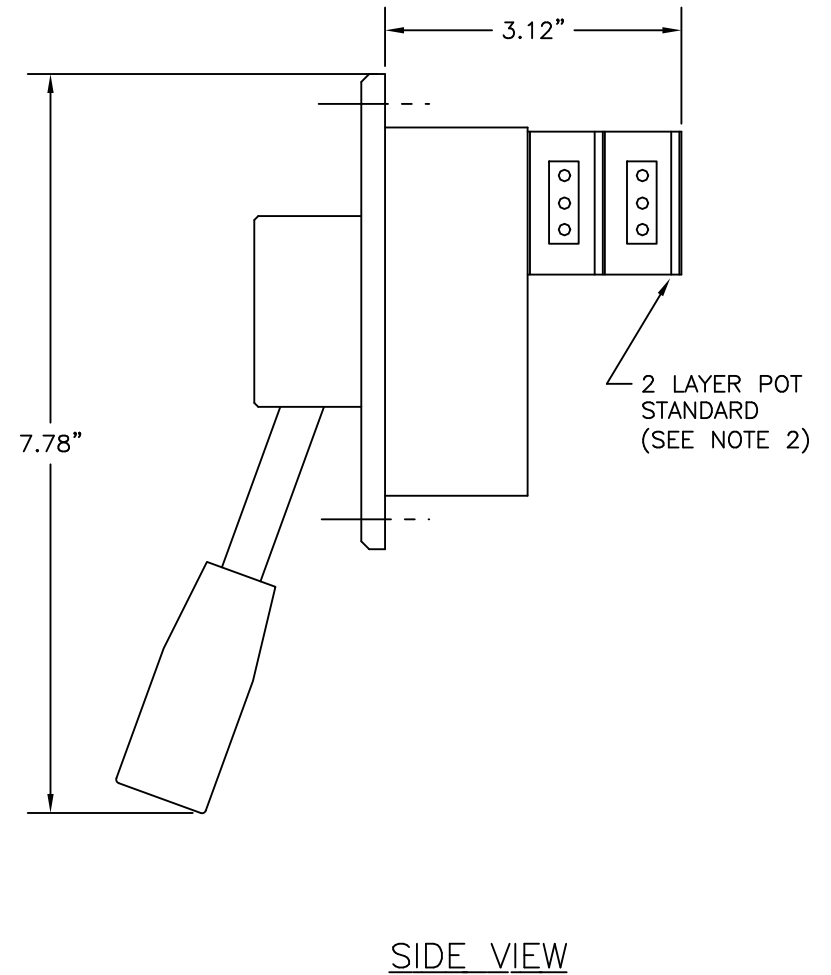
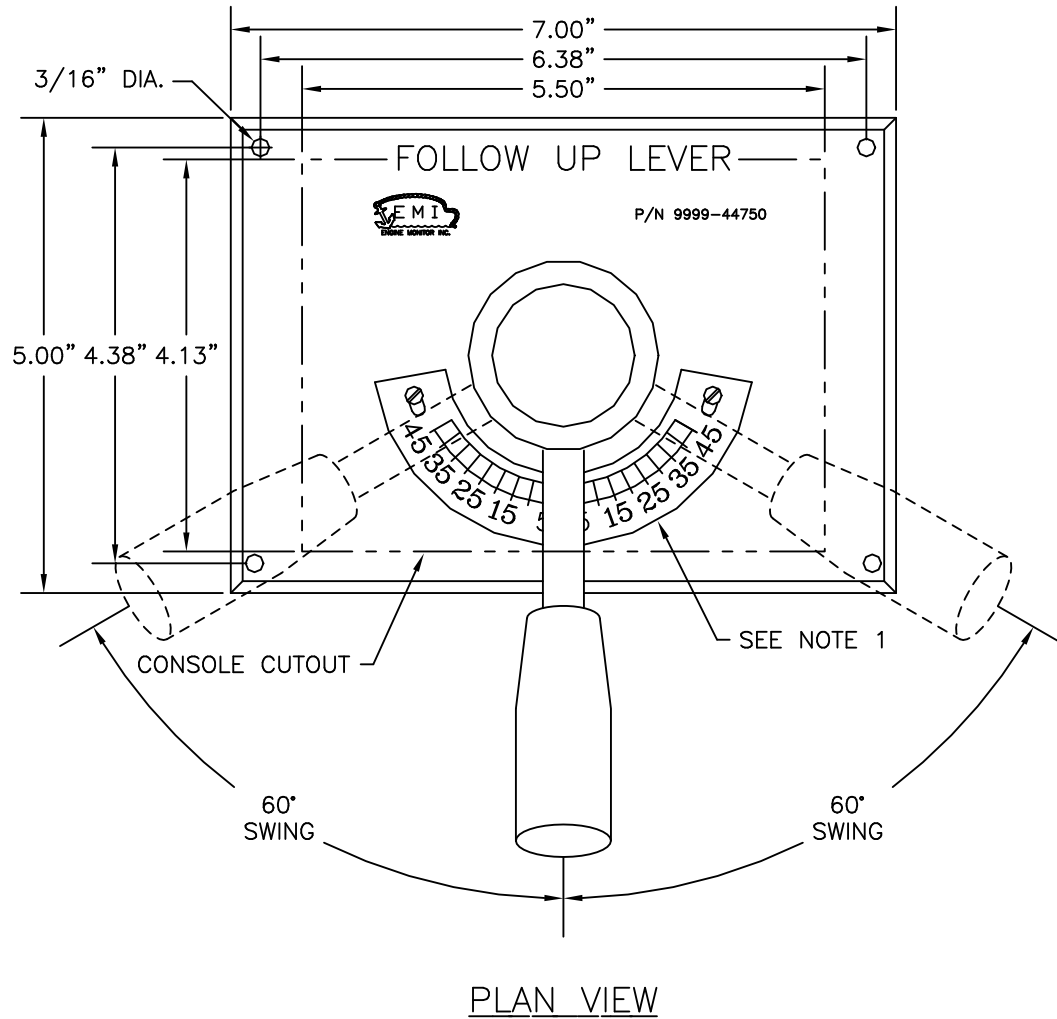

EMI
ENGINE MONITOR, INC.
191 JAMES DRIVE WEST
SAINT ROSE, LA 70087

PHONE: (504) 620-9800
FAX: (504) 620-9801
E-MAIL: emonitor@emi-marine.com
WEBSITE: www.emi-marine.com

FULL FOLLOW-UP STEERING LEVER

DWG:

44750

DATE: 6/30/00 SHEET 1 REV:-- FILE: 44750

THIS DRAWING CONTAINS PROPRIETARY INFORMATION AND DESIGNS OWNED BY ENGINE MONITOR, INC. (E.M.I.). ALL DESIGNS, MANUFACTURING, REPRODUCTION, USE, PATENT RIGHT, AND SALES RIGHTS REGARDING THE SAME ARE EXPRESSLY RESERVED BY ENGINE MONITOR, INC.