

GENERAL NOTES
 1. ALLOW 5.00" INCHES FOR PANEL DEPTH.
 2. CONSOLE CUTOOUT SHOULD BE 8.5" x 7.5"

BILL OF MATERIAL

ITEM	QTY	DESCRIPTION	EMI PART No.	MFR PART No.	MANUFACTURER
1	1	MOUNTING PLATE	7000-77064S-M	7000-77064S-M	EMI
2	1	BACKPLATE	1200-77064S-61	1200-77064S-61	EMI
3	4	INDICATOR	2450-00013	31-040,005	EAO
4	4	LENS, GREEN	2450-00021G	31-903,5	EAO
5	4	LAMP, 24V	2450-00008	334	SYLVANIA
6	1	POTENTIOMETER, 500, 2W	4750-00051	53C3500	CLAROSIAT
7	1	DIMMER KNOB	2400-00006	PKCS60B 1/4	AUGAT
8	1	PUSHBUTTON	5100-00069	8411K11	CUTLER HAMMER
9	1	SWITCH SELECTOR 6 LAYER	5100-00001	21306A	ELECTROSWITCH
10	1	DIODE PCB	9999-44080	9999-44080	EMI
11	8.25"	DIN RAIL, T35, 7.5MM	2100-00465	0801733	PHOENIX
12	2	END STOP	2100-00576	249-117	WAGO
13	2	END PLATE, TERMINAL	2100-00698	281-324	WAGO
14	30	FEEDTHROUGH TERMINAL BLOCK, 3 WIRE	2100-00648	281-681	WAGO
15	2	TERMINAL MARKER, 1-50	2100-00497	209-566	WAGO
16	2	TERMINAL POST	2100-00577	249-119	WAGO
17	1	END PLATE	2100-00603	870-518	WAGO
18	2	TERMINAL BLOCK 4 WIRE DOUBLE DECK	2100-00604	870-501	WAGO
19	1	TERMINAL MARKER +/-	2100-00606	793-552	WAGO

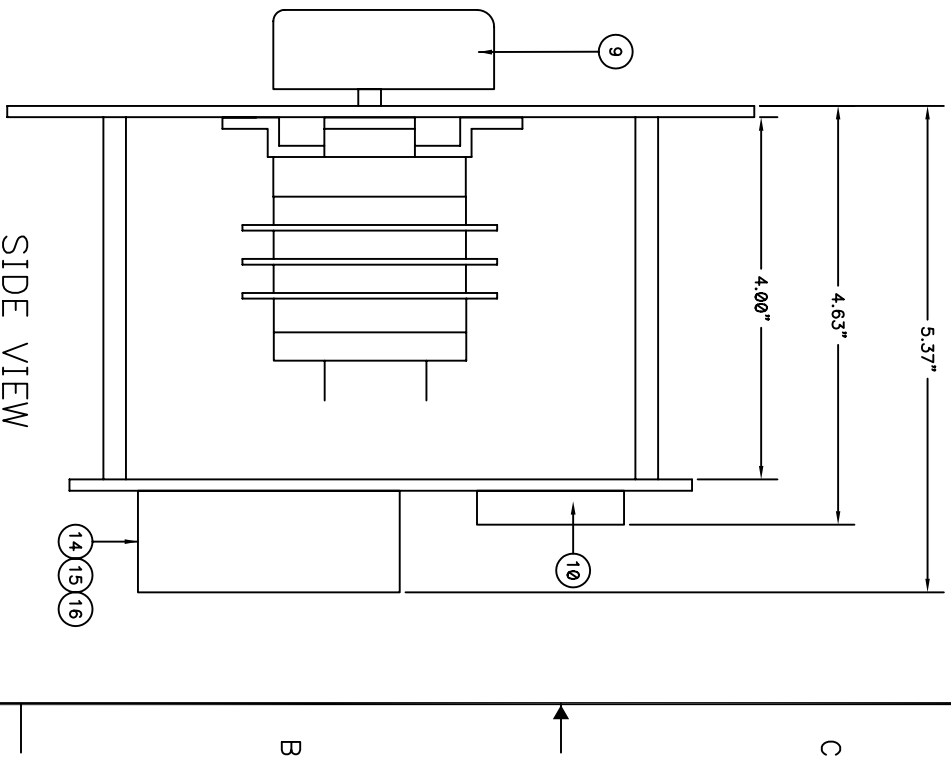
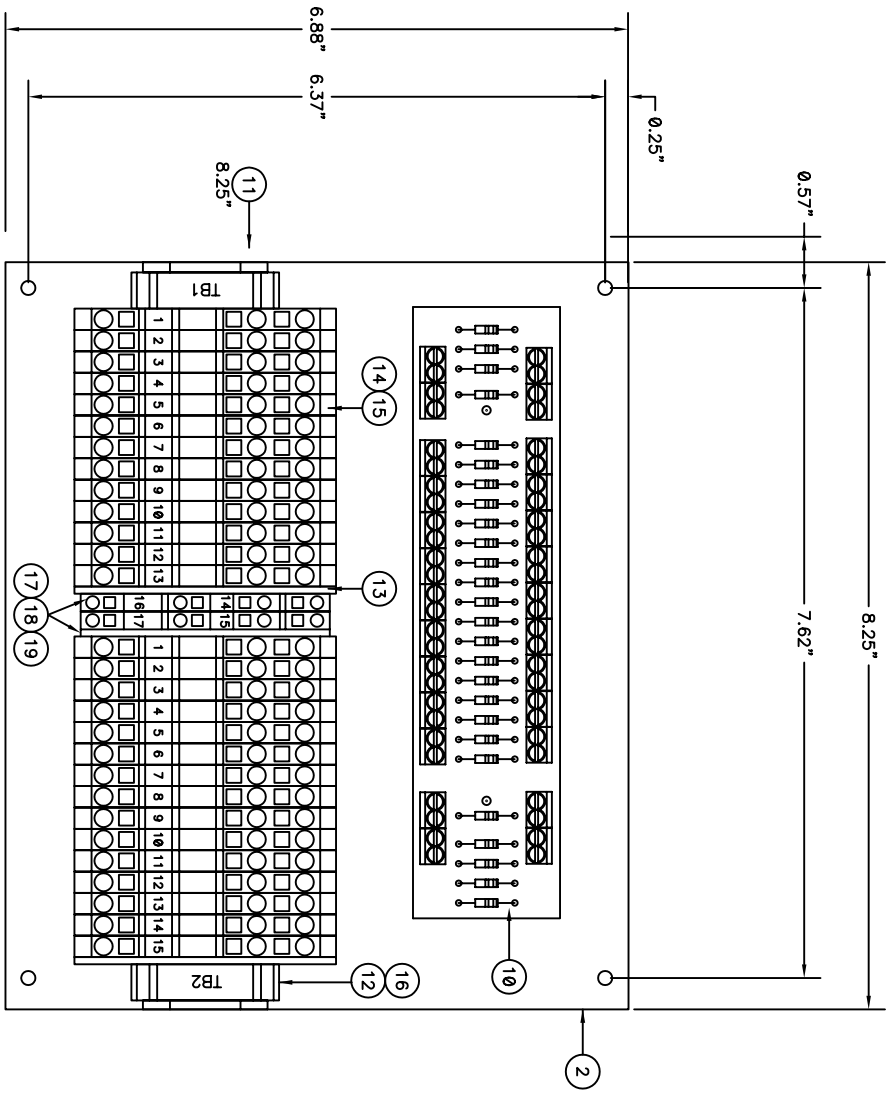
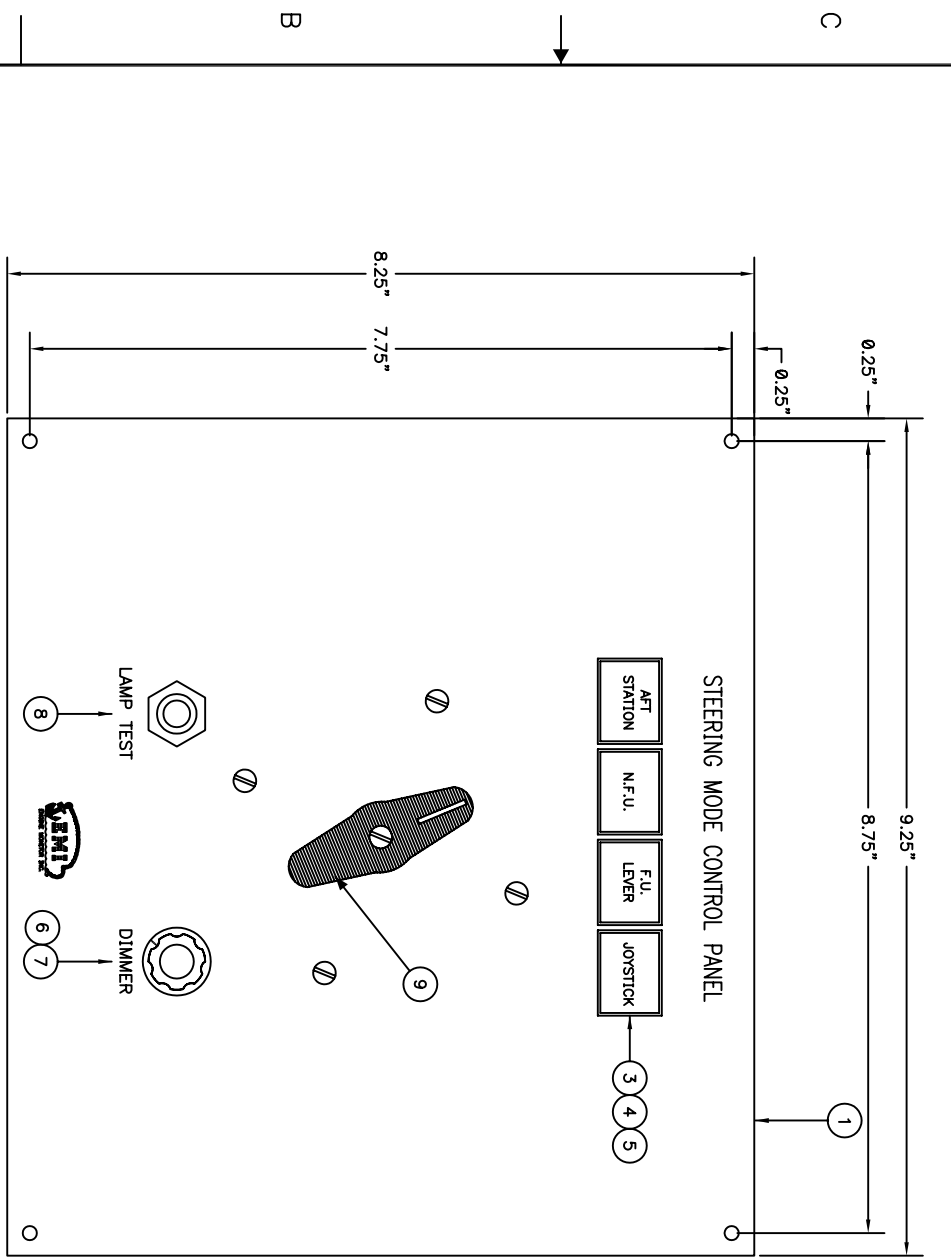

MOUNTING PLATE

BACK PLATE

THIS DRAWING CONTAINS PROPRIETARY INFORMATION AND DESIGNS OWNED BY ENGINE MONITOR, INC. (E.M.I.). ALL DESIGNS, MANUFACTURING, REPRODUCTION, USE, PATENT RIGHTS, AND SALES RIGHTS REGARDING THE SAME ARE EXPRESSLY RESERVED BY ENGINE MONITOR INC.

REFERENCES

REF NO.	DRAWING NO.	DESCRIPTION
1	44080	DIODE PCB

REV ZONE ITEM

REV	ZONE	ITEM	DESCRIPTION	DATE	BY

191 JAMES DRIVE WEST
 ST. ROSE, LA 70087

EMI

PILOTHOUSE STEERING
 MODE CONTROL
 PANEL

SCALE: 1/2" = 1"

SHEET 1 OF 2